



Unbeatable price-performance ratio. Increase production, improve flexibility, reduce rejects.

Turned part measurement solutions providing rapid return on investment.



M1

Compact and ergonomic, the ideal tool to flank multi-spindle lathes or sliding head lathes.

From simple fittings to small shafts measuring up to 300x60 mm.



M2

Perfect for small turned parts or large shafts up to 600x140 mm.



M Series

Now even faster, this series reduces measuring times and sets a new bar in its sector.

The live image of the part displayed by the software, combined with the LED illuminated extensive working area, gives a clear vision of the conditions of the component being measured.

The retractable sensors enabled during loading and unloading provide reinforcement, with additional one of a kind protective bumpers.

The ergonomic piece clamping lever has a considerably wide grip, which is suitable both for left and right-handed operators and prevents obstruction of the view when clamping or unclamping the part.

The M series measures small components as easily as large shafts, capturing the finest details such as ridges and radii.

M2 and M3 offer an increased load capacity that allows elements up to 240 mm in diameter to be positioned.

M3

Designed to measure shafts up to 900x140 mm.



Quality without compromise.

The variety of the range ensures benchmark reliability.



From 40 to 180 mm in diameter, and 300 to 1250 mm in length, the modular range of the Techno series can provide you with the most suitable machine for your production.



Techno Series



The machine improves productivity.

Operators are more independent during inspection and tool offsets can be adjusted before parts become out of tolerance in order to reduce the amount of rejects produced.

Dimensional control directly on the shop floor.

Each part produced by the CNC lathe can be easily measured by operators within the production environment.

Greater productivity also on smaller batches.

Batch changing is fast and efficient.

One measuring system for multiple CNC lathes.

A single system can operate next to multiple machining centers, involving more than one operator.

High resolution.

Detailed images capture even minute features.

No more compromises.

Given the wide scope of measurement ranges offered, this machine range is designed to adapt to current and future manufacturing demands.

Tested reliability.

Specific expertise and carefully selected components have created a highly efficient range of solutions.

Heavy Duty.

The load capacity of the largest machines has increased by up to 60 kg.



The best way to measure small components.

A clear-cut solution for dental implantology, biomedical technology, the watch-making industry and micromechanic applications.



MTL X5

The ideal tool for dental implantology and micromechanics in general.

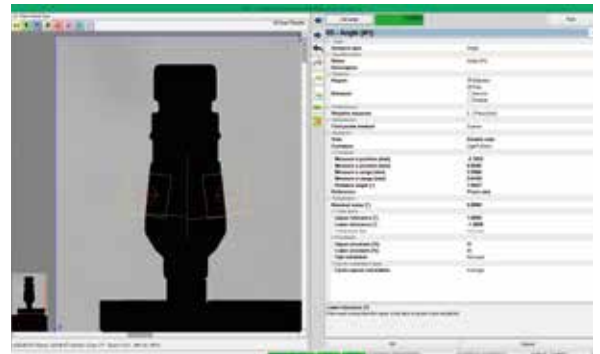
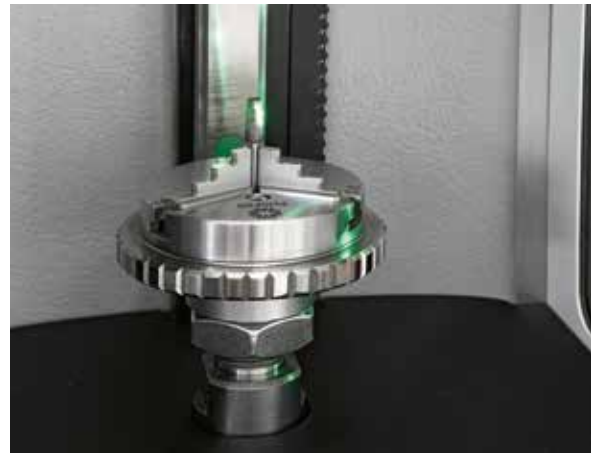

MTL X10

Designed for the watch-making industry.



X Series

X series has been specifically designed to measure dental implants, biomedical components, watch parts and micromechanics.

Thanks to the high resolution, one-of-a-kind in its category, it detects even the smallest details. Measuring tools designed for every need: static measurements, hexagon and thread analysis.

The open design facilitates direct access and handling of even the smallest and most complex cylindrical components.

The configuration with a fixed component and optical unit in movement prevents the piece from vibrating or falling off during measurement, especially in the case of very small parts which are difficult to hold steady.

As there are no openings or undercuts in the machine, there is no risk of small parts falling into the works.

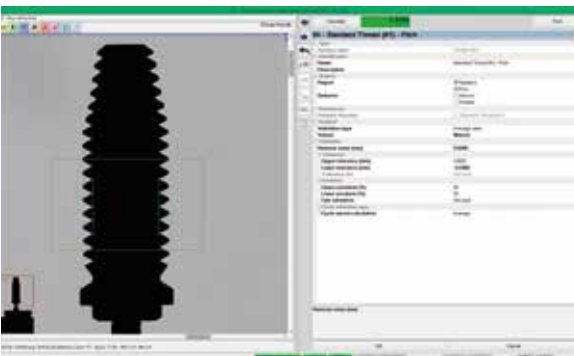



In our daily life, evaluating our current operations confirms a correct working practice and ensures us that we are on the right track.

That's why VICIVISION brings inspection to the place where it offers the greatest advantage: directly on the production floor.

Increased productivity, improved efficiency and flexibility, and a reduction in rejection rates are the immediate advantages.

With more than 40 years of experience and a worldwide sales and service network, VICIVISION provides optimal solutions for the inspection of turned parts.



Fast and accurate.

Quality control can be a costly process in terms of time and labor. For this reason, carrying out measurements with a single tool means saving time, manpower and improving the accuracy of inspection.

MTL includes the functions of profile projectors, micrometers, roundness gauges, etc. eliminating human error in acquiring measurements and allowing operators to manage the acquired data.

Static measurements: Diameters
Lengths
Angles
Chamfers
Radii
Mean sphere diameters

Nut measurements: Keys
Asymmetries
Angular timings

DXF comparison: Distances from profile
Distances from tolerance
GD&T

Geometric measurements: Symmetries
Parallelisms
Orthogonalities
Straightnesses

Special application tool: Camshafts
Crankshafts
Turbine wheels

Thread measurements: Nominal diameters
Core diameters
Mean diameters
Crest angles
Helix angles
Pitches
Roll dimensions
NG diameter dimensions
LG dimensions

Form measurements: Rotation diameters
Roundnesses
Coaxialities
Axial and radial run-out
Cylindricities
Angular timings
Planes parallelisms
Tapers
Dynamic parallelisms

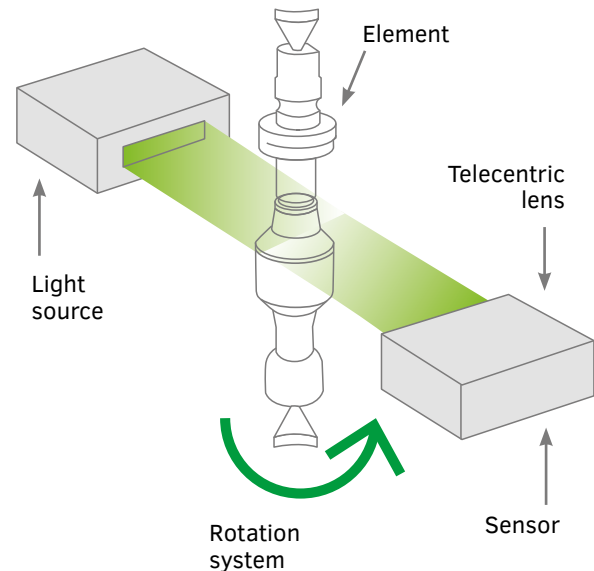

TRADITIONAL MEASUREMENT SYSTEM

Measurement takes from 10 to 30 minutes.
Data is conditioned by human interference.
Difficult to use.
Requires data collection.



Projector

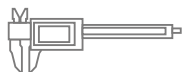

Micrometer

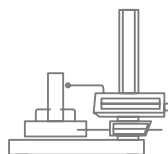

Roundness gauge

VICIVISION MEASUREMENT SYSTEM

Measurement takes from 30 to 60 seconds.
No more human error.
Automatic cycle by pressing a button.
Automatic data collection.

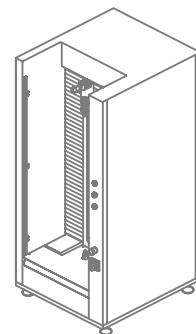

Increasing your production.

MTL is an optical measuring machine for turned and ground parts, capable of taking measurements in a matter of seconds on a part profile directly on the shop floor.



SPEEDING UP BATCH CHANGE

Save up to 1 hour on each batch, measuring the components directly beside the CNC lathe.



KEEPING PRODUCTION IN TOLERANCE.

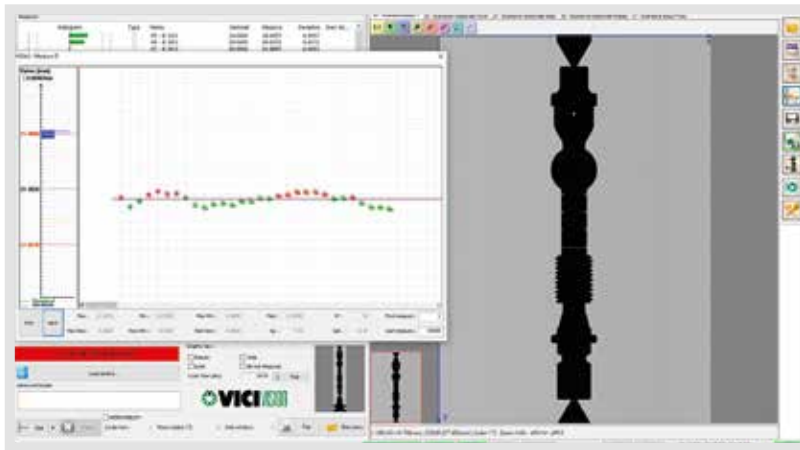

Reduction in machine downtime thanks to immediate inspection without the need to leave the workstation.

Significant reduction in rejects, implementing the preventive actions indicated by the measurement trend graphs.

VICIVISION TOOL-LOOP

It is possible to set the interface between MTL and the workstation to automatically correct tool parameters. This function eliminates human error and speeds up tool parameter settings. Each part produced is ready to be delivered.



Greater efficiency on smaller batches.

The first part of every batch must be measured to set the machining center. Performing this operation with MTL beside your machine saves up to 1 hour and increases efficiency even on small batches.



FIXING ACCESSORIES

There is a full range of accessories that meet all the needs to fix components.



BARCODE READER

Move from one piece to another by scanning the barcode.



LIVE MEASUREMENTS

Once the live image of the component has been captured, the software collects all the static measurement data and instantly issues a report for each component measured.

Missing some dimensions? The operator can detect them directly from the image.



POSSIBILITY TO INTEGRATE ROBOTICS

Automatic loading and unloading means 100% inspection of production without additional costs.

Measuring form defects on the shop floor.

MTL can detect form measurements directly on the shop floor, where tools like roundness gauges might not withstand the environmental conditions. In a matter of seconds it is possible to take:

ROUNDNESS

AXIAL AND RADIAL RUN-OUT

COAXIALITY

CYLINDRICITY

DYNAMIC PARALLELISM

ALSO FOR THREADED COMPONENTS

It is possible to take form measurements on threaded components such as nuts, bolts and pivots. Multi-rotation and software filtering systems take form measurements also on elements with high roughness.

Form measurements can also be taken on portions of interrupted diameters such as splined shafts or the external diameters of gears or turbines.

These measurements can also be detected on eccentric elements, including camshafts.

3D CILINDRICITY GRAPH

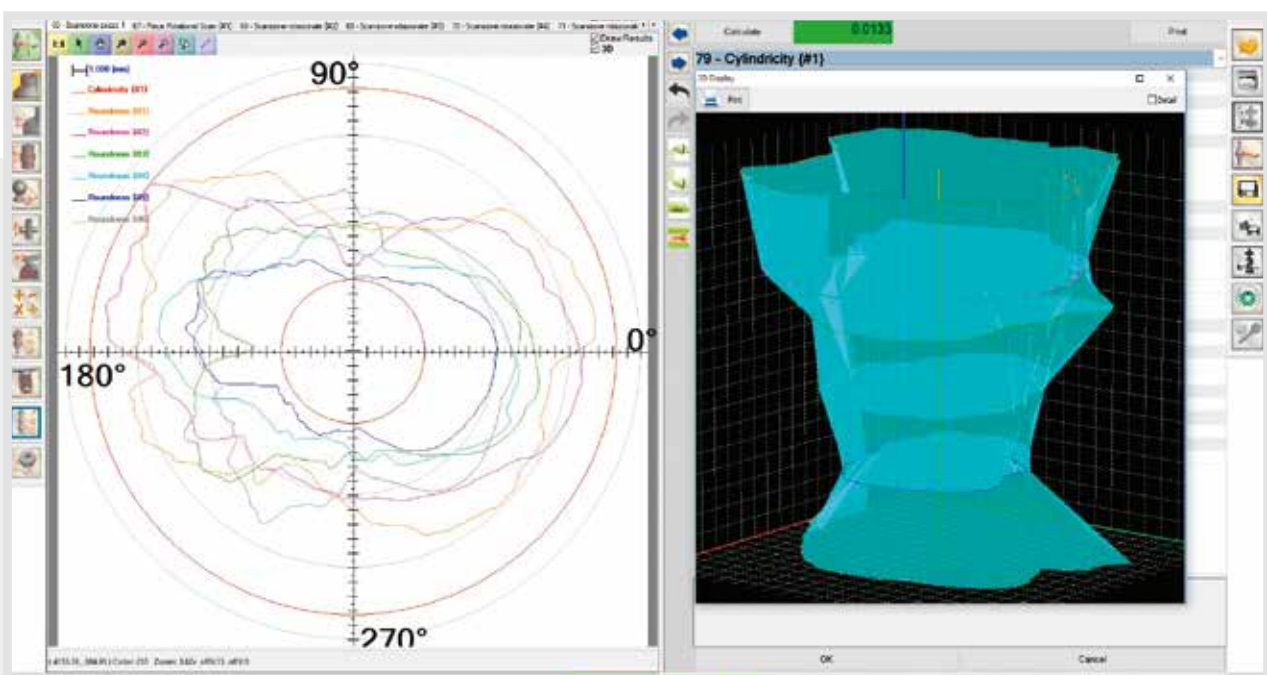



MEASURING THREADS

MTL measures different threads in a matter of seconds.

Programming standard threads is faster, as the machine is fitted with pre-filled charts that include nominal values and tolerances.

On threads it is possible to measure nominal diameters, internal diameters, mean diameters, crest angles, pitches, roll dimensions, LG values, etc.

THREADING, FOR CUTTING OR ROLLING?

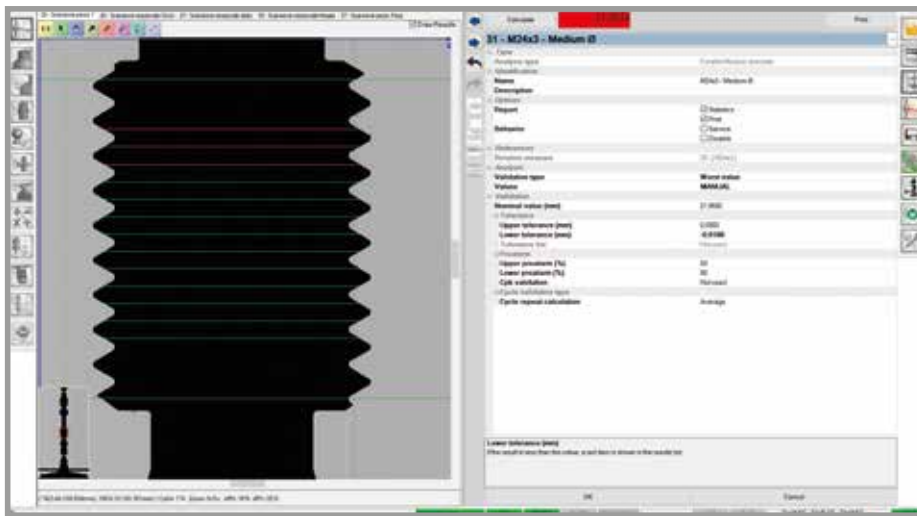

VICIVISION has developed thread measuring tools to meet its clients' needs.

For each parameter it is possible to validate the mean value of the full thread, or alternatively, each crest can be validated, highlighting which parts of the thread are within tolerance, borderline, or out of tolerance.

Mean value validation is

ideal for those who produce threading by swarf removal.

The validation of each thread crest is indicated for production by identifying rolling where roll wear can result in half the thread being in tolerance and the other half out of tolerance.

FORM MEASUREMENTS ON THREADED PIVOT

MTL measures the run-out, the oscillation of the pin's under head in relation to the threaded part.

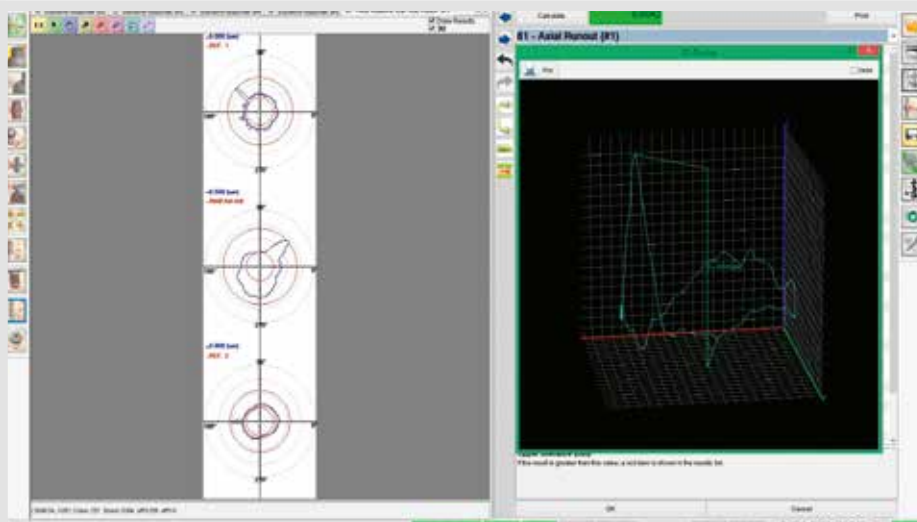



MEASURING CAMSHAFTS

MTL software has specific tools to measure camshafts. By simply inserting some data, such as the basic radius of the cam, the type of tappet and the law of motion, you obtain:

- confirmation of the basic radius
- the maximum height of the cam
- deviation of the calculated profile from the theoretical profile
- deviation of acceleration
- the run-out of the basic profile.

MEASURING CRANKSHAFTS

MTL offers solutions for crankshaft pin measurements, such as stroke, diameter, roundness, cylindricity, run-out and timings.



MEASURING TURBINES

Dynamically determines the position of the known diameter on the turbine wheel, as well as making a DXF profile comparison.



FOCUS ON TECHNOLOGY

An on board step-master ensures proper machine functioning.



Retractable sensors protect optics from part damage during loading and unloading.

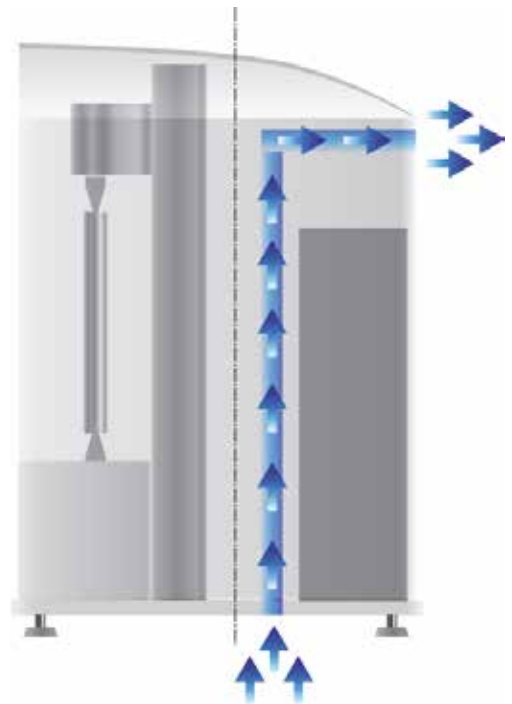

Unique "Air flow" cooling system for use even in the toughest environments.



Tailstocks slides on prismatic guides with ball runner blocks guaranteeing precision that lasts. Rack and pinion regulation system for easy use.

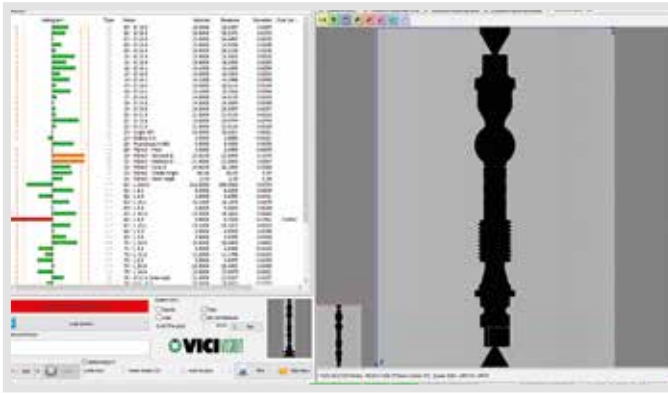

DIRECT DISPLAY OF LIVE IMAGE OF THE PART

Allows the operator to check that the measurement has not been contaminated by burrs or dirt.

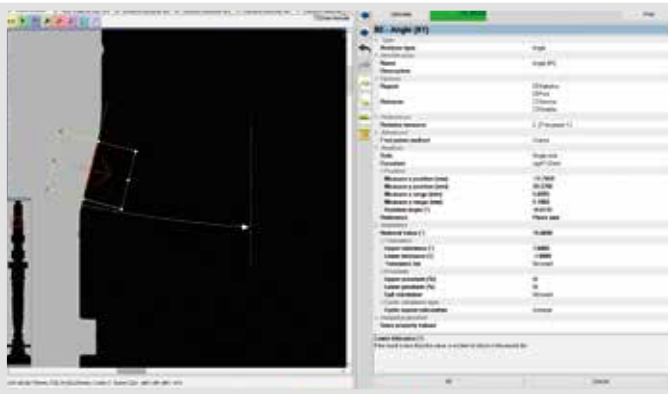

OFF-LINE PROGRAMMING

Create measurement programs from the comfort of your desk while the machine is used by operators.

- Program on the live image of a part or start from DXF and choose the blocking systems from the database.

- By saving the programs on the server, multiple MTL units can be programmed.

- Load images from the archives, re-inspecting previously measured parts without actually having the part, useful in the case of prototyping, safety components or disputes from clients regarding delivered parts.

- It can be used for reverse engineering, manually detecting the profile dimensions.

WIDE LOADING AREA AND OPEN-TOP DESIGN



TELESERVICE

Remote support from a VICIVISION technician for diagnosis, updates and assistance with programming complex elements.

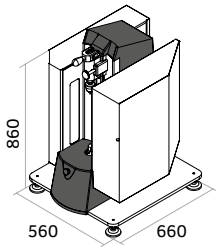

LAYOUT 1

MTL X5
MTL X10

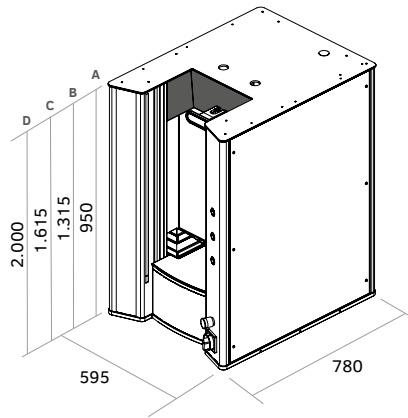

LAYOUT 2

A M1 M304 M306 M309
B M604 M606 M609
C M906 M909
D M1209

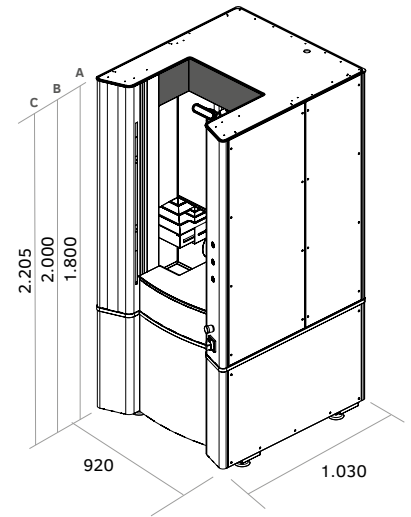

LAYOUT 3

A M314 M318
B M2 M3 M614 M618 M914 M918
C M1214 M1218

	LAYOUT	Measuring field	Max. loadable sizes	Accuracy Ø - L	Repeatability Ø - L	Size LxDxH mm	Power supply		
							Voltage	Frequency	Nominal power
MTL X10	LAYOUT 1	100x8 mm	270x90 mm - 3Kg	2+D[(mm)/100] µm 5+L[(mm)/100] µm	0,4 µm / 3 µm	560x660x860 mm	230 V	50/60 Hz	1,73 A
MTL X5	LAYOUT 1	100x16 mm	270x90 mm - 3Kg			560x660x860 mm			
M1	LAYOUT 2/A	300x60 mm	315x120 mm - 10Kg	2+D[(mm)/100] µm 5+L[(mm)/100] µm	0,4 µm / 3 µm	595x780x950 mm	230 V	50/60 Hz	1,73 A
M2	LAYOUT 3/B	600x140 mm	625x240 mm - 30Kg			920x1030x2000 mm			
M3	LAYOUT 3/B	900x140 mm	925x240 mm - 30Kg			920x1030x2000 mm			
M304	LAYOUT 2/A	300x40 mm	315x120 mm - 10Kg	1,5 + D[(mm)/200] µm 4 + L[(mm)/200] µm	0,3 µm / 1,2 µm	595x780x950 mm	230 V	50/60 Hz	1,73 A
M306	LAYOUT 2/A	300x60 mm	315x120 mm - 10Kg			595x780x950 mm			
M309	LAYOUT 2/A	300x90 mm	315x120 mm - 30Kg			595x780x950 mm			
M314	LAYOUT 3/A	300x140 mm	315x240 mm - 30Kg			920x1030x1800 mm			
M318	LAYOUT 3/A	300x180 mm	315x240 mm - 30Kg	920x1030x1800 mm					
M604	LAYOUT 2/B	600x40 mm	625x120 mm - 30Kg	1,5 + D[(mm)/200] µm 4 + L[(mm)/200] µm	0,3 µm / 1,2 µm	595x780x1315 mm	230 V	50/60 Hz	1,73 A
M606	LAYOUT 2/B	600x60 mm	625x120 mm - 30Kg			595x780x1315 mm			
M609	LAYOUT 2/B	600x90 mm	625x120 mm - 30Kg			595x780x1315 mm			
M614	LAYOUT 3/B	600x140 mm	625x240 mm - 30Kg			920x1030x2000 mm			
M618	LAYOUT 3/B	600x180 mm	625x240 mm - 30Kg			920x1030x2000 mm			
M906	LAYOUT 2/C	900x60 mm	925x120 mm - 30Kg	1,5 + D[(mm)/200] µm 4 + L[(mm)/200] µm	0,3 µm / 1,2 µm	595x780x1615 mm	230 V	50/60 Hz	1,73 A
M909	LAYOUT 2/C	900x90 mm	925x120 mm - 30Kg			595x780x1615 mm			
M914	LAYOUT 3/B	900x140 mm	925x240 mm - 60Kg			920x1030x2000 mm			
M918	LAYOUT 3/B	900x180 mm	925x240 mm - 60Kg			920x1030x2000 mm			
M1209	LAYOUT 2/D	1250x90 mm	1300x120 mm - 30Kg	2+D[(mm)/100] µm 5+L[(mm)/100] µm	0,4 µm / 3 µm	595x780x2000 mm	230 V	50/60 Hz	1,73 A
M1214	LAYOUT 3/C	1250x140 mm	1300x240 mm - 60Kg			920x1030x2205 mm			
M1218	LAYOUT 3/C	1250x180 mm	1300x240 mm - 60Kg			920x1030x2205 mm			



Vici & C S.p.A.

Via J. Gutenberg, 5 - 47822 Santarcangelo di Romagna (RN)
tel. +39 0541-350411 - fax +39 0541-623897
www.vicivision.com - sales@vici.it